

SYSTEM HOST BOARD WITH MULTI-CORE PROCESSORS

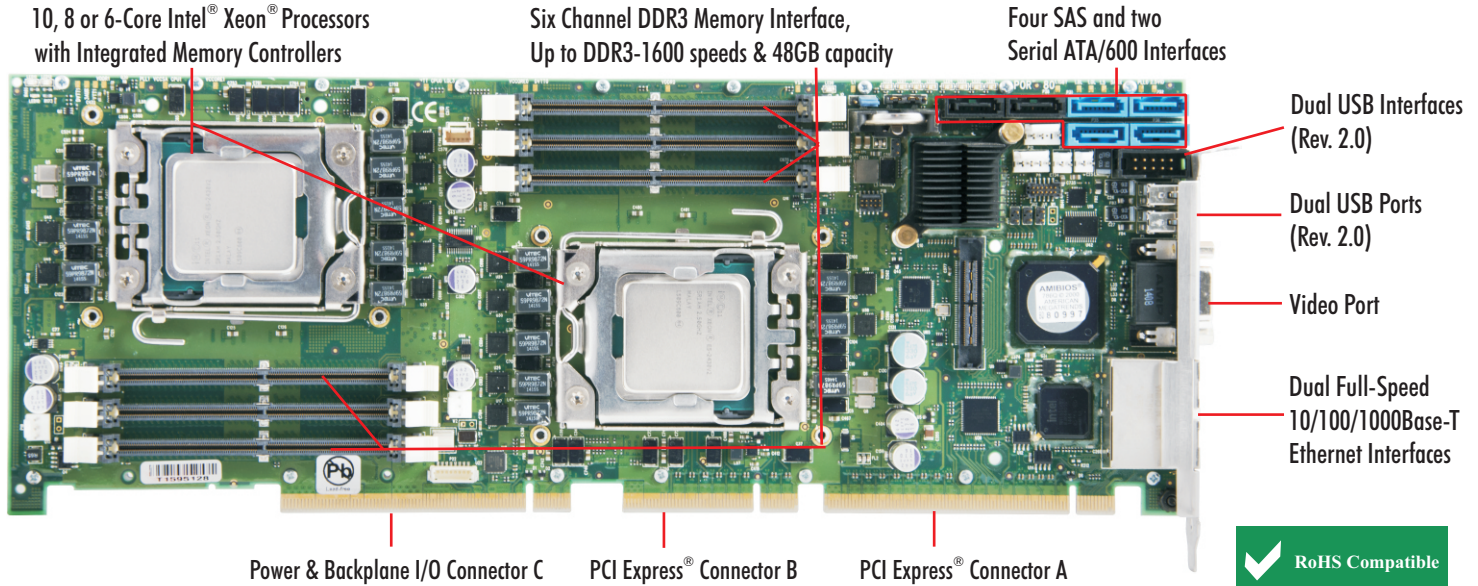

Here's a brief list of the BXT7059 single board computer highlights:

- System performance boost with 10, 8 or 6-core CPU architecture
- On-board power management and system security features
- Deployment risks lowered with extended-life board design
- 5-year product warranty maximizes system ROI
- On-board interface support for either SAS or SATA/300 drives
- Built-in system support for PCI Express 1.1, 2.0 and 3.0 cards

PROCESSORS:

Intel® Xeon® E5-2400 v2 Series Processors (1.8GHz - 2.5GHz)*
Processor Package: LGA1356 *10, 8 and 6-core options available

The DDR3 integrated memory controllers in select Intel® Xeon® E5-2400 v2 series processors support DDR3-1600 memory interface speeds. The PCI Express® 3.0 links available directly out of the processors allow BXT7059 system designs that deliver faster performance in a wide variety of data intensive applications. Other features include:

- Extended-life, embedded components provide longevity
- 22nm Intel® Micro-Architecture design (by Bridge-EN) saves power
- Ten, eight & six-core micro-architecture with Intel® Hyper-Threading doubles core processing capability (all E5-2400 v2 options)
- Intel® Turbo Boost Technology (E5-2448L v2, 2418L v2 & 2430 v2 CPUs)
- Intel® AVX Float 16 supported on all E5-2400 v2 series processors
- Native PCI Express Gen 3.0 links support all PCIe devices

PLATFORM CONTROLLER HUB (PCH):

The Intel® C604 is a Platform Controller Hub (PCH) that takes the place of the traditional multi-component chipset. The PCH design approach saves power while providing enhanced system host board I/O, PCI Express and Ethernet interface capabilities.

THREE ETHERNET INTERFACES - 10/100/1000BASE-T:

The BXT7059 supports three Gigabit Ethernet interfaces. Two ports are located on the board's I/O bracket and a third LAN is routed for use on cable header P22 or as a PICMG 1.3 backplane interface via SHB edge connector C. Trenton has a 24" (610mm) cable available (part no. 193-500001150-00) for use with P22 that has the mating P22 connector on one end and an Ethernet LAN connector mounted into an I/O plate on the other.

PCI EXPRESS® GEN 3.0, 2.0 and 1.1 INTERFACES:

Trenton's BXT7059 supports system designs with one x16, two x8 or four x4 PCI Express® links on a PICMG® 1.3 backplane. These links plus an additional x4 PCIe link (B0) and eight PCIe reference clocks are supplied on SHB edge connectors A & B. Link B0 may also function as four, x1 PCIe links. Trenton's optional IOB33 and PEX10 modules can be used on the board to provide additional x4 and x16 PCIe expansion links to the system. Upon system power-up, the BXT7059 automatically configures all of the PCIe links between the board and PCIe target devices for optimum data communication. This automatic link negotiation process may result in data transfer communications between the SHB and the system option cards to take place at either PCI Express 3.0, 2.0 or 1.1 link speeds. The actual link speed will be determined by a number of factors such as PCI Express endpoint types, system backplane design and other system design parameters. PCI Express auto-negotiation between the BXT7059 and the system option cards is fully supported thereby enabling system design support for x1, x4, x8 and x16 PCI Express cards.

PCI EXPRESS CONFIGURATION:

- PCI Express - Edge Connectors - One x16, two x8 or four x4 A & B links, plus one x4 or 4 - x1 links - Eight reference clocks
- PCI Express - IOB33 - One x4 link
- PCI Express - PEX10 - One x16 or 2 - x8 or 4 - x4 links

VIDEO:

Trenton's BXT7059 SHB features a Graphics Processing Unit (GPU) driven with a x1 PCIe link from the PCH of the board. The GPU has 8MB of on-board video memory to support pixel resolutions up to 1920 x 1200 (WUXGA) with a 64K color depth.

DDR3-1600 MEMORY INTERFACE:

The BXT7059's memory interface is a six-channel interface with three channels on each Intel® Xeon® E5-2400 v2 Series Processor. The long-life Intel® Xeon® E5-2448L v2 operates at the DDR3-1600 memory interface speed with peak data transfer rates up to 1600 MT/s per channel. All processors shall use DDR3-1600 Mini-DIMMs on the SHB; however, CPUs like the Intel® Xeon® E5-2418L v2 will clock-down to the DDR3-1333 memory interface speed. ECC registered memory must be used on the BXT7059 and Trenton recommends PC3-12800, DDR3-1600 Mini-DIMMs for all BXT7059 processor options. A maximum memory capacity of 48GB is supported when using 8GB DDR3 Mini-DIMMs.

SERIAL ATTACHED SCSI & SERIAL ATA PORTS:

An integrated Serial Attached SCSI (SAS) / Serial ATA (SATA) controller in the Intel® C604 PCH provides support for either four SAS and two SATA ports or six SATA ports. Two SATA ports deliver data transfer rates up to 600MB/s while the remaining four ports support 300MB/s transfers. Independent SAS/SATA drive operation and RAID drive array configurations are supported. An additional SATA/300 interface is routed to edge connector C for use on a backplane.



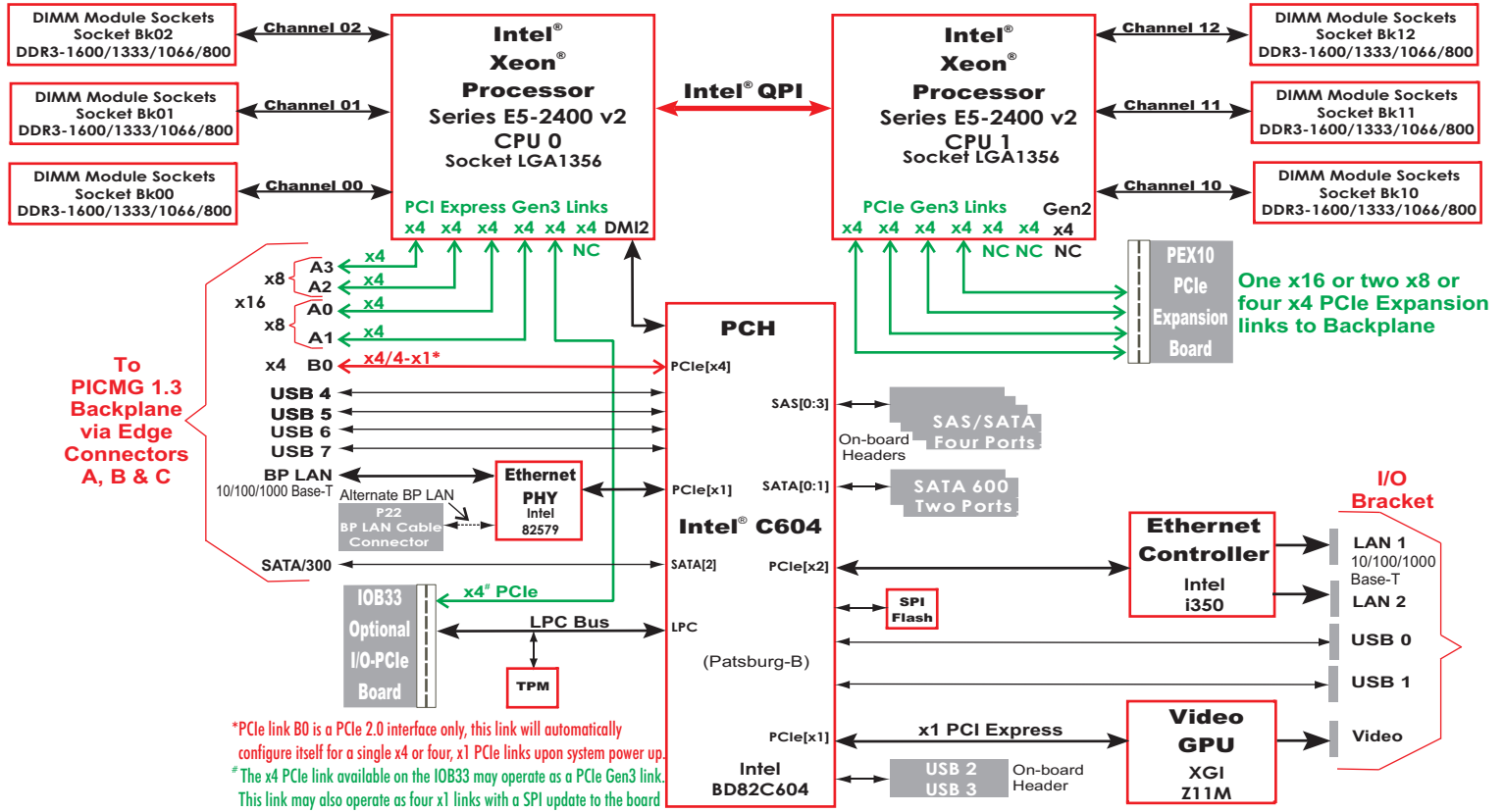

UNIVERSAL SERIAL BUS INTERFACES (USB 2.0):

There are eight USB 2.0 interfaces on the BXT7059 SHB. USB ports 0 and 1 are located on the I/O bracket, on-board header contain ports 2 and 3, and USB ports 4, 5, 6 and 7 are routed to the SHB's edge connector C for use on backplanes that support the optional PICMG 1.3 USB interface capability.

OPTIONAL PEX10 PCI EXPRESS LINK EXPANSION:

An optional PEX10 PCIe expansion board has a x16 PCIe edge connector that routes additional PCI Express links from the rear connector on the BXT7059 SHB down to a system backplane. This enables expanded x4, x8 and x16 system interface capabilities beyond the PICMG 1.3 specification.

ADDITIONAL PRODUCT FEATURES:

I/O Features:

- Optional IOB33 expansion board provides:
 - x4 PCIe link routing to backplane PCIe Expansion Slot
 - Enhanced bi-directional parallel interface
 - PS/2 mouse and keyboard interface (mini DIN connector)
 - Floppy drive interface and two high-speed serial ports
- The BXT7059 provides a watchdog timer (WDT) with seven programmable timeout periods of 32 msec., 128 msec., 512 msec., 1 sec., 4 sec., 8 sec. or 32 sec. When enabled the WDT generates a system reset. WDT control is supplied via the General Purpose I/O pins from the Intel® C604 Platform Controller Hub (PCH).

BIOS (FLASH):

BXT7059 board use Aptio® 4.x BIOS from American Megatrends, Inc. or AMI. The board's BIOS resides in the SHB's SPI Flash device to simplify field upgrades and BIOS customization.

APPLICATION CONSIDERATIONS:

Power Requirements:

Typical Values* - Static Desktop (Idle) with 24GB of system memory

CPU	Intel® No.	+5V	+12V	+3.3V
2.5GHz	E5-2450 v2 ⁸	1.65A	6.66A	3.11A
2.5GHz	E5-2430 v2 ⁶	1.56A	5.22A	3.21A
1.8GHz	E5-2448L v2 ¹⁰	1.66A	5.58A	3.03A
1.8GHz	E5-2428L v2 ⁸	1.58A	4.96A	3.05A
2.0GHz	E5-2418L v2 ⁶	1.48A	4.13A	2.98A

Typical Values* - 100% Stress State with 24GB of system memory

CPU	Intel® No.	+5V	+12V	+3.3V
2.5GHz	E5-2450 v2 ⁸	1.93A	19.57A	3.55A
2.5GHz	E5-2430 v2 ⁶	1.72A	12.32A	3.21A
1.8GHz	E5-2448L v2 ¹⁰	1.68A	12.60A	3.11A
1.8GHz	E5-2428L v2 ⁸	1.72A	10.07A	3.23A
2.0GHz	E5-2418L v2 ⁶	1.62A	8.31A	3.19A

10 = Ten-core CPU, 8 = Eight-core CPU, 6 = Six-core CPU

Note: All CPUs have Intel® Hyper-Threading

*These are typical power numbers; actual power numbers will vary as a function of the specific BXT7059 system configuration design.

Temperature/Environment:

Operating: 0° to 50° C. (0° to 40° C. when using E5-2450 v2 processors)

Storage: - 40° to 70° C.

Air Flow Requirement: 350LFM continuous airflow

Humidity: 5% to 90% non-condensing

Mechanical:

The cooling solution on the BXT7059 is approximately 2.15" (54.61mm) from the top component side of the SHB and the dimensions are 13.330"/33.858cm L x 4.976"/12.639cm/H.

STANDARDS:

- PCI Express® Base Specifications 3.0, 2.0 and 1.1
- SHB Express® System Host Board PCI Express Specification - PCI Industrial Computer Manufacturers Group (PICMG®) 1.3

ORDERING INFORMATION:

Part Number	CPU Speed	Intel® No. #
92-705970400000	2.5GHz	E5-2450 v2 ^{8,5}
92-705971700000	2.5GHz	E5-2430 v2 ^{6,5}
92-705972200000	1.8GHz	E5-2448L v2 ^{10,5}
92-705973200000	1.8GHz	E5-2428L v2 ^{8,5}
92-705974300000	2.0GHz	E5-2418L v2 ^{6,T}

All E5-2400 v2 processor options are long-life embedded CPUs, 10 = Ten-core, 8 = Eight-core, 6 = Six-core, S = DDR3-1600, T = DDR3-1333 max memory interface speed, All CPUs have Intel® Hyper-Threading

AGENCY APPROVALS:

UL60950, CAN/CSA C22.2 No. 60950-00, EN55022:1998 Class B, EN61000-4-2:1995, EN61000-4-3:1997, EN61000-4-4:1995, EN61000-4-5:1995, EN61000-4-6:1996, EN61000-4-11:1994

The stated processing, memory and communication interface speeds and bandwidths are component maximums; actual system performance may vary.

Intel, Intel Xeon, Intel Hyper-Threading Technology, Intel VT, Intel AVX, Intel TXT and Intel DCMI are trademarks or registered trademarks of Intel Corporation. All other product names are trademarks of their respective owners

Copyright ©2017 by TRENTON Systems Inc. All rights reserved



IoT Solutions Alliance

