

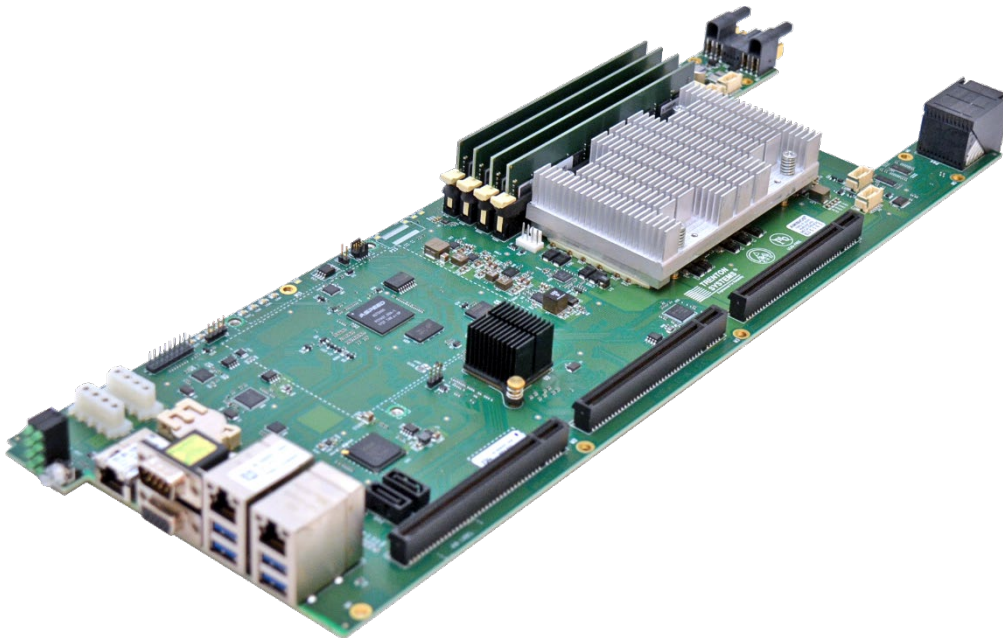

# Manual

# MBK8257



**Prepared by**

Trenton Systems  
1725 MacLeod Dr  
Lawrenceville, GA 30043

**Date:** April 30, 2020

**Model Number:** MBK8257

**Revision:** 1

## Table of Contents

Preface .....	2
About Trenton Systems .....	3
Warranty & Policies .....	4
Handling Precautions .....	7
Regulatory Compliance .....	8
System Overview .....	11
Diagrams & Layouts .....	13
Technical Specifications .....	15



# Preface

The information in this user's manual has been carefully reviewed and is believed to be accurate. Trenton Systems assumes no responsibility for any inaccuracies that may be contained in this document and makes no commitment to update or to keep current the information in this manual, or to notify any person or organization of the updates.

**Please Note:** For the most up-to-date version of this manual, please visit our website at: [www.trentonsystems.com](http://www.trentonsystems.com).

Trenton Systems, Inc. reserves the right to make changes to the product described in this manual at any time and without notice. This product, including software and documentation, is the property of Trenton Systems and/or its licensors, and is supplied only under a license. Any use or reproduction of this product is not allowed, except as expressly permitted by the terms of said license.

IN NO EVENT WILL TRENTON SYSTEMS, INC. BE LIABLE FOR DIRECT, INDIRECT, SPECIAL, INCIDENTAL, SPECULATIVE OR CONSEQUENTIAL DAMAGES ARISING FROM THE USE OR INABILITY TO USE THIS PRODUCT OR DOCUMENTATION, EVEN IF ADVISED OF THE POSSIBILITY OF SUCH DAMAGES. IN PARTICULAR, TRENTON SYSTEMS, INC. SHALL NOT HAVE LIABILITY FOR ANY HARDWARE, SOFTWARE, OR DATA STORED OR USED WITH THE PRODUCT, INCLUDING THE COSTS OF REPAIRING, REPLACING, INTEGRATING, INSTALLING OR RECOVERING SUCH HARDWARE, SOFTWARE, OR DATA.

## Contact Information

Trenton Systems, Inc.  
1725 MacLeod Drive  
Lawrenceville, GA 30043  
(770) 287-3100

info@trentonsystems.com  
sales@trentonsystems.com  
support@trentonsystems.com

[www.trentonsystems.com](http://www.trentonsystems.com)



# About Trenton Systems

“Unbelievably light. Unquestionably rugged. Undeniably powerful.”

## BACKGROUND

Since its establishment in 1989, Trenton Systems has been the leading, high-performance computer hardware and systems manufacturer dedicated to crafting application-specific solutions for the military, industrial and commercial markets. Our rugged computing solutions are designed and manufactured in-house at our state-of-the-art facility in Lawrenceville, Georgia, which we relocated to in 2016 after outgrowing our original facility in Gainesville. Versatile, adaptable and built-to-last, our multi-faceted computing solutions sport completely customizable, ultra-rugged designs, both inside and outside the chassis.

## EXPERIENCE

Trenton Systems is trusted by the world's leading technology companies. Some of our happy customers include Boeing, IBM, L3Harris, Northrop Grumman, Lockheed Martin and Raytheon. We also partner with Intel via the Embedded and Communications Alliance, which provides us with access to Intel's roadmap, as well as with technical support directly from the company.

Throughout the years, we've been at the forefront of the industry in numerous capacities. As a founding member of the PCI Industrial Manufacturers Group (PICMG), we redefined the industry in 1994 with our PICMG 1.0 form factor, and redefined it again in 2005, when we wrote the PICMG 1.3 specification. In 2008, we streamlined our design and manufacturing capabilities, allowing us to craft our systems fully in-house and provide customers with a one-stop shop for all things Trenton rugged.

## PHILOSOPHY

Trenton Systems believes in stress-testing and certifying its USA-made products to and beyond the highest military and industrial standards. We believe in crafting solutions that last decades, rather than just a few years. We believe in providing rapid and effective follow-up support so that our customers don't have to spend hours, days or weeks trying to resolve a simple issue. At Trenton, we believe in setting our customers up for success, both on and off the front lines.



# Warranty & Policies

## WARRANTY

The following is an abbreviated version of Trenton Systems' warranty policy for processor board products. For a complete warranty statement, contact Trenton Systems or visit our website at [www.trentonsystems.com](http://www.trentonsystems.com).

Board-level products manufactured by Trenton Systems are warranted against material and manufacturing defects for five years from date of delivery to the original purchaser. Buyer agrees that if this product proves defective Trenton Systems, Inc. is only obligated to repair, replace or refund the purchase price of this product at Trenton Systems' discretion. The warranty is void if the product has been subjected to alteration, neglect, misuse or abuse; if any repairs have been attempted by anyone other than Trenton Systems, Inc.; or if failure is caused by accident, acts of God, or other causes beyond the control of Trenton Systems, Inc. Trenton Systems, Inc. reserves the right to make changes or improvements in any product without incurring any obligation to similarly alter products previously purchased.

In no event shall Trenton Systems, Inc. be liable for any defect in hardware or software or loss or inadequacy of data of any kind, or for any direct, indirect, incidental or consequential damages arising out of or in connection with the performance or use of the product or information provided. Trenton Systems, Inc.'s liability shall in no event exceed the purchase price of the product

## RETURN POLICY

A Service Order Number, obtained from Trenton Systems prior to return, must accompany products returned for repair. The customer must prepay freight on all returned items, and the customer is responsible for any loss or damage caused by common carrier in transit. Items will be returned from Trenton Systems via Ground, unless prior arrangements are made by the customer for an alternative shipping method.

To obtain a Service Order Number, call us at (800) 875-6031 or (770) 287-3100 or email our Technical Support Team at [support@trentonsystems.com](mailto:support@trentonsystems.com). We will need the following information:

- ▶ Return company address and contact
- ▶ Model name and model # from the label on the back of the product
- ▶ Part Number and Serial number from the label on the product
- ▶ Description of the failure and failure mode



The Part Number and Serial Number are listed on the chassis as shown here:

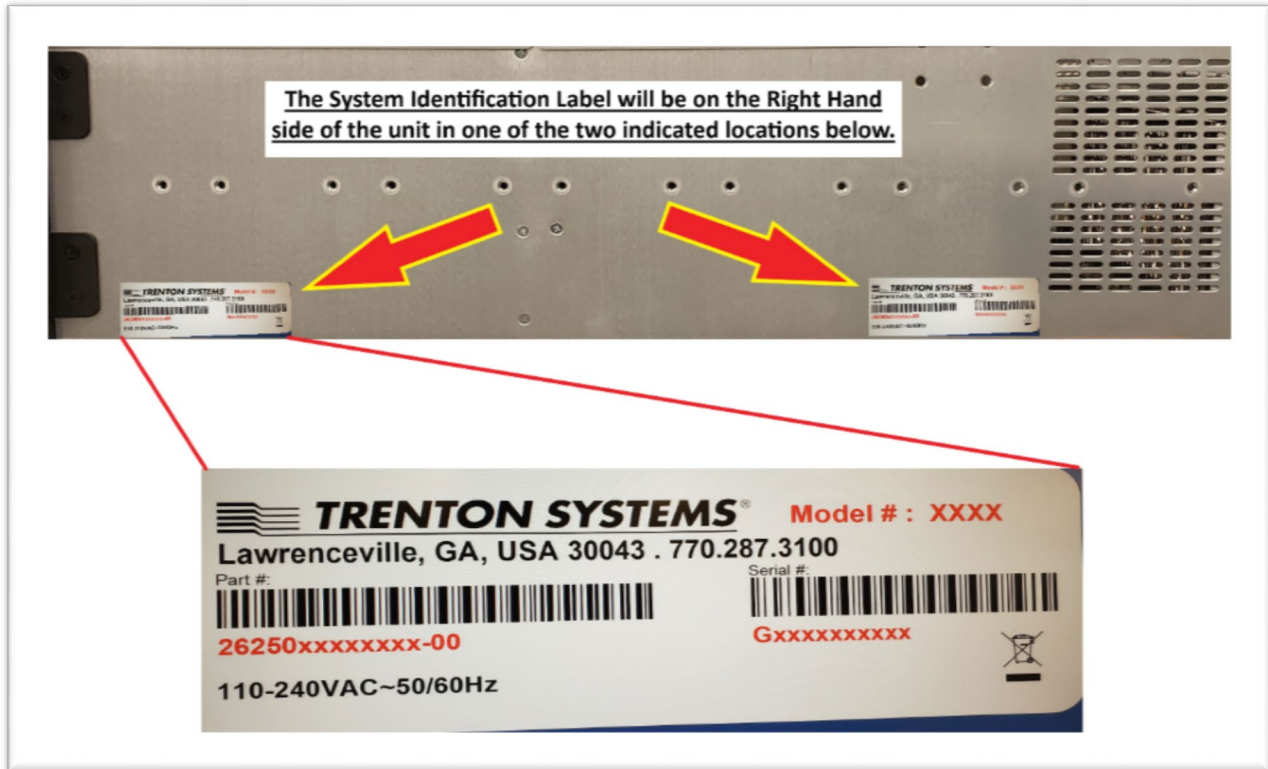

Here is an Example label, which shows the Part Number, Revision and Serial Number (S/N):



A Service Order Number will be issued. Mark the Service Order Number clearly on the outside of each box, include a copy of the Service Order failure report for each board and return the product(s) to our Lawrenceville, GA facility:

Trenton Systems, Inc.  
1725 MacLeod Drive  
Lawrenceville, GA 30043  
Attn: Repair Department

## TRADEMARKS

- ▶ IBM, PC/AT, VGA, EGA, OS/2 and PS/2 are trademarks or registered trademarks of International Business Machines Corp.



---

## Section 2 / Warranty & Policies

- ▶ AMI and APTIO are trademarks of American Megatrends Inc.
- ▶ Intel, Xeon, Intel Core, Intel AMT, Intel TXT, Intel Hyper-Threading Technology and Intel Virtualization Technology are trademarks or registered trademarks of Intel Corporation.
- ▶ MS-DOS and Microsoft are registered trademarks of Microsoft Corp.
- ▶ PCI Express is a trademark of the PCI-SIG
- ▶ All other brand and product names may be trademarks or registered trademarks of their respective companies.

### LIABILITY DISCLAIMER

This manual is as complete and factual as possible at the time of printing; however, the information in this manual may have been updated since that time. Trenton Systems, Inc. reserves the right to change the functions, features or specifications of their products at any time, without notice.

Copyright © 2019 by Trenton Systems, Inc. All rights reserved.

E-mail: [support@trentonsystems.com](mailto:support@trentonsystems.com)

Web: [www.trentonsystems.com](http://www.trentonsystems.com)



# Handling Precautions



**WARNING:** This product has components that may be damaged by electrostatic discharge.

To protect your processor board from electrostatic damage, be sure to observe the following precautions when handling or storing the system:

- ▶ Keep the processor board in its static-shielded bag until you are ready to perform your installation.
- ▶ Handle the processor board by its edges.
- ▶ Do not touch the I/O connector pins.
- ▶ Do not apply pressure or attach labels to the processor board.
- ▶ Use a grounded wrist strap at your workstation or ground yourself frequently by touching the metal chassis of the system before handling any components. The system must be plugged into an outlet that is connected to an earth ground.
- ▶ Use antistatic padding on all work surfaces.
- ▶ Avoid static-inducing carpeted areas.

## Recommended Processor Board Storage Precautions

This SHB has components on both sides of the PCB. Some of these components are extremely small and subject to damage if the board is not handled properly. It is important for you to observe the following precautions when handling or storing the board to prevent components from being damaged or broken off:

- ▶ Store the board in padded shipping material or in an anti-static board rack.
- ▶ Do not place an unprotected board on a flat surface.



**WARNING:** There is danger of explosion if the CMOS battery is replaced incorrectly. Disposal of battery into fire or a hot oven, or mechanically crushing or cutting of a battery can result in an explosion.





# Regulatory Compliance

## DECLARATION OF CONFORMITY

### FCC

This device complies with part 15 of the FCC rules as a Class A device. Operation is subject to the following two conditions: (1) this device may not cause harmful interference and (2) this device must accept any interference received, including interference that might cause undesired operation.

### CE

This equipment complies with all applicable European Union (CE) directives if it has a CE marking. For this device to remain CE compliant, only CE compliant parts can be installed, and proper cables and cabling techniques are required.

## AGENCY APPROVALS

**All standards should be at applicable revision levels at time of test.**

- ▶ Electromagnetic Emissions (EMI)
  - Designed to meet FCC 47 CFR Part 15 Subpart B ISSED Canada ICES-003 Issue 6 Class A as a minimum.
  - Designed to meet Electromagnetic Compatibility Directive 2014/30/EU
  - Immunity Product Standard: EN55035:2017
  - Emissions Product Standards: EN55032:2012, EN 61000-3-2:2014, EN61000-3-3:2013

### Safety

- ▶ This product will be UL approvable for safety concerns and designed for IEC 60950-1:2005 and IEC 62368-1:2014

### Environmental

- ▶ This product will be approvable for MIL-STD-810G High and Low-Temp Operating and Storage system testing to test methods 501.5 and 502.5, Procedures II and I
- ▶ This product will be approvable for MIL-STD-810G Altitude Operational and Storage system testing to test method 500.5, Procedures II and I.
- ▶ TRC1002 with MBK8257 has been tested to and passed MIL-STD-461G, CE102, and RE102 requirements.



## INTRODUCTION

It is important to be aware of the system considerations listed below before installing your MBK8257 (8257-xxx) processor board. Overall system performance may be affected by incorrect usage of these features.

## DDR4-2400 MEMORY

Trenton Systems recommends unbuffered ECC DDR4-2400 PC4-19200 memory modules for use on the MBK8257. The MBK8257 supports a maximum of 64GB of memory using two channels across four DIMM slots.

### NOTES:

- ▶ To maximize memory interface speed, populate each memory channel with DDR4 DIMMs having the same interface speed. The processor board will support DIMMs with different speeds, but the memory channel interface will operate speed of the slowest DIMM.
- ▶ All memory modules must have gold contacts.
- ▶ All memory modules must have a 288-pin edge connector
- ▶ The processor board supports the following memory module memory latency timings:
  - 17-17-17-39 for 2400MHz DDR4 DIMMs
- ▶ Populate the memory sockets starting with memory channel A and begin by using the DIMM socket closest to the CPU first. Refer to the MBK8257 board layout drawing and populate the memory sockets using the population order illustrated in the chart below:

POPULATION ORDER	CPU1
1	BK0A
2	BK1A
3	BK0B
4	BK1B

- ▶ Using a balanced memory population approach ensures maximum memory interface performance. A “balanced approach” means using an even number of DIMMs on the MBK8257 processor board whenever possible.
- ▶ The memory DIMMs on the processor board connect directly to the CPU and at least one memory module must be installed on the board.



## **SATA RAID OPERATION (WINDOWS O/S SETUP)**

The Intel® C236 Platform Controller Hub (PCH) used on the processor board features Intel® Rapid Storage Technology (Intel® RST) and requires unique drivers.

## **BIOS**

The MBK8257 features the Aptio® BIOS from American Megatrends, Inc. (AMI) with a ROM-resident setup utility called the Aptio Text Setup Environment or TSE.

## **OPERATING SYSTEMS**

Trenton Systems has successfully tested the MBK8257 processor board with a wide variety of contemporary operating systems including Linux (Red Hat RHEL, Centos and SUSE), Windows® 8.1, Windows® 10, Windows® 2012 Server, and Windows® 2016 Server.



# System Overview

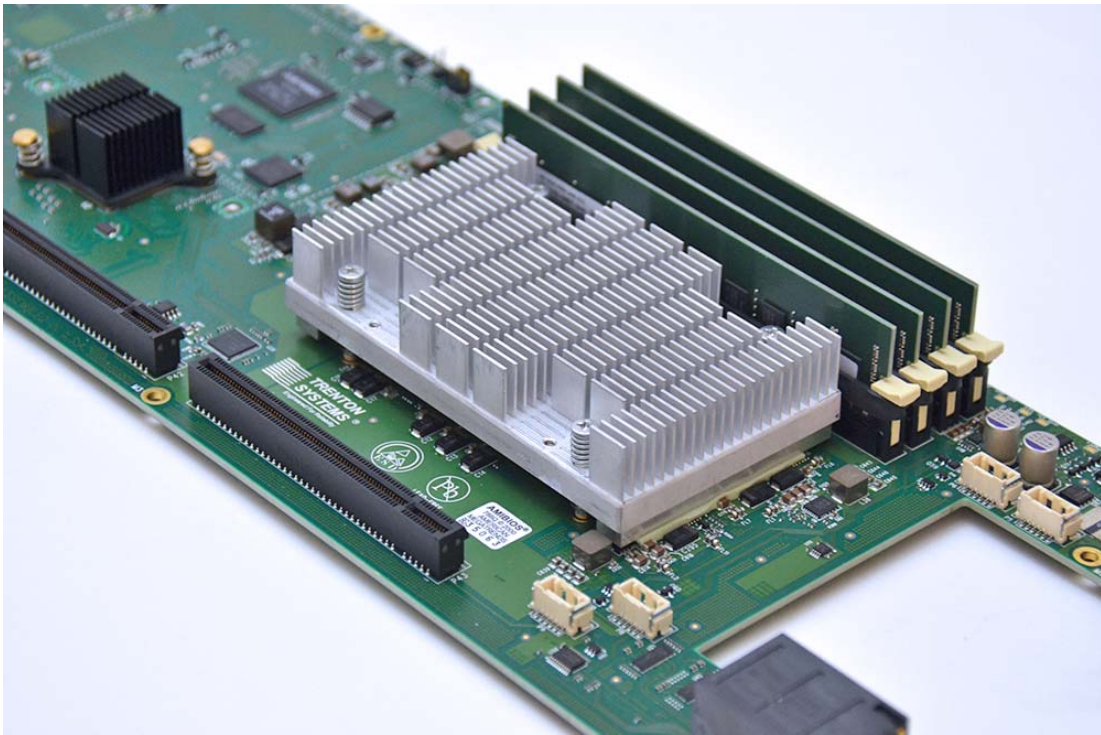

**Figure 1: MBK8257**

Exceptional performance, modular design, and long-life components backed by made in USA reliability.



## Section 6 / System Overview

### MODEL NUMBER

MBK8257

### PROCESSORS

- ▶ Intel® Core i3, i5, i7 Series & E3-1275 v6 Processors
- ▶ CPU TDP support up to 125W

Processor	Frequency	ECC	Cores/Threads
i7-7700T	2.9 GHz	No	4/8
i5-7500T	2.7 GHz	No	4/4
i3-7101TE	3.4 GHz	Yes	2/4
E3-1275 v6	3.8 GHz	Yes	4/8

### MEMORY

- ▶ **Slots:** 4x DDR4 DIMM sockets
- ▶ **Capacity:** Up to 64GB
- ▶ **Type:** 2400 ECC DDR4 DIMM
- ▶ **DIMM Sizes:** 16GB, 8GB
- ▶ **Error Detection:** Corrects single-bit errors and detects double-bit errors using ECC memory

### STORAGE

- ▶ **SATA:** 2x SATA 3.0 (6 Gbps) (front)
- ▶ **Optional:** 4x M.2 NVMe PCIe 3.0 x4

### ON-BOARD DEVICES

- ▶ **Chipset:** Intel® C236
- ▶ **IPMI:** Support for Intelligent Platform Management Interface v2
  - IPMI 2.0 with virtual media over LAN and KVM-over-LAN support
  - ASPEED AST2400 BMC
- ▶ **SATA:** 2x SATA 3 (6 Gbps)
- ▶ **Network Controllers:**
  - 1x Intel® i350 Dual Gigabit Ethernet
  - 1x Intel® i210 Gigabit Ethernet
  - Supports 10BASE-T, 100BASE-TX, and 1000BASE-T, RJ-45 output
- ▶ **Graphics:** ASPEED AST2400 BMC; VGA 1920x1200@60Hz 32bpp

### INPUT / OUTPUT

- ▶ **Power:** 1x Power Connector
- ▶ **USB:** 4x USB 3.0 Ports
- ▶ **Display:** 1x VGA Port
- ▶ **LAN:**
  - 2x RJ-45 Gigabit Ethernet LAN ports
  - 1x RJ-45 Dedicated IPMI LAN port
- ▶ **Serial:** 1x RS232 Serial Port

### DIMENSIONS

Width: 6.19" | 15.72 cm

Length: 17.62" | 44.74 cm

Average Weight\*: 4.6 lbs. | 2.09 kg

\*dependent on component selection

### SYSTEM COOLING

4x 40mm Fans; DC 12 V

### SYSTEM BIOS

**BIOS Type:** 128 Mb SPI NOR Flash with AMI BIOS

#### BIOS Features:

- ▶ Plug and Play (PnP)
- ▶ TPM 2.0
- ▶ PCI 2.2
- ▶ ACPI 1.0 / 2.0
- ▶ USB Keyboard Support
- ▶ SMBIOS 2.3
- ▶ UEFI

### MANAGEMENT

AST2400 Baseband Management Controller: rKVM, System Monitoring, Out of Band Management, On-board TPM 2.0

### ENVIRONMENTALS

- ▶ Operating Temperature: 0°C - 45°C
- ▶ Storage Temperature: -40°C - 70°C
- ▶ Operating Humidity: 8% - 90% Non-Condensing
- ▶ Non-operating Humidity: 5% - 95% Non-Condensing

### COMPLIANCE

Trenton Systems Model TRC1002 with MBK8257 tested and passed RTCA/DO-160G (Section 21) Category B and Category M.

Trenton Systems Model TRC1002 with MBK8257 tested and passed MIL-STD-461G, CE102, and RE102 requirements.



# Diagrams & Layouts

## BLOCK DIAGRAM

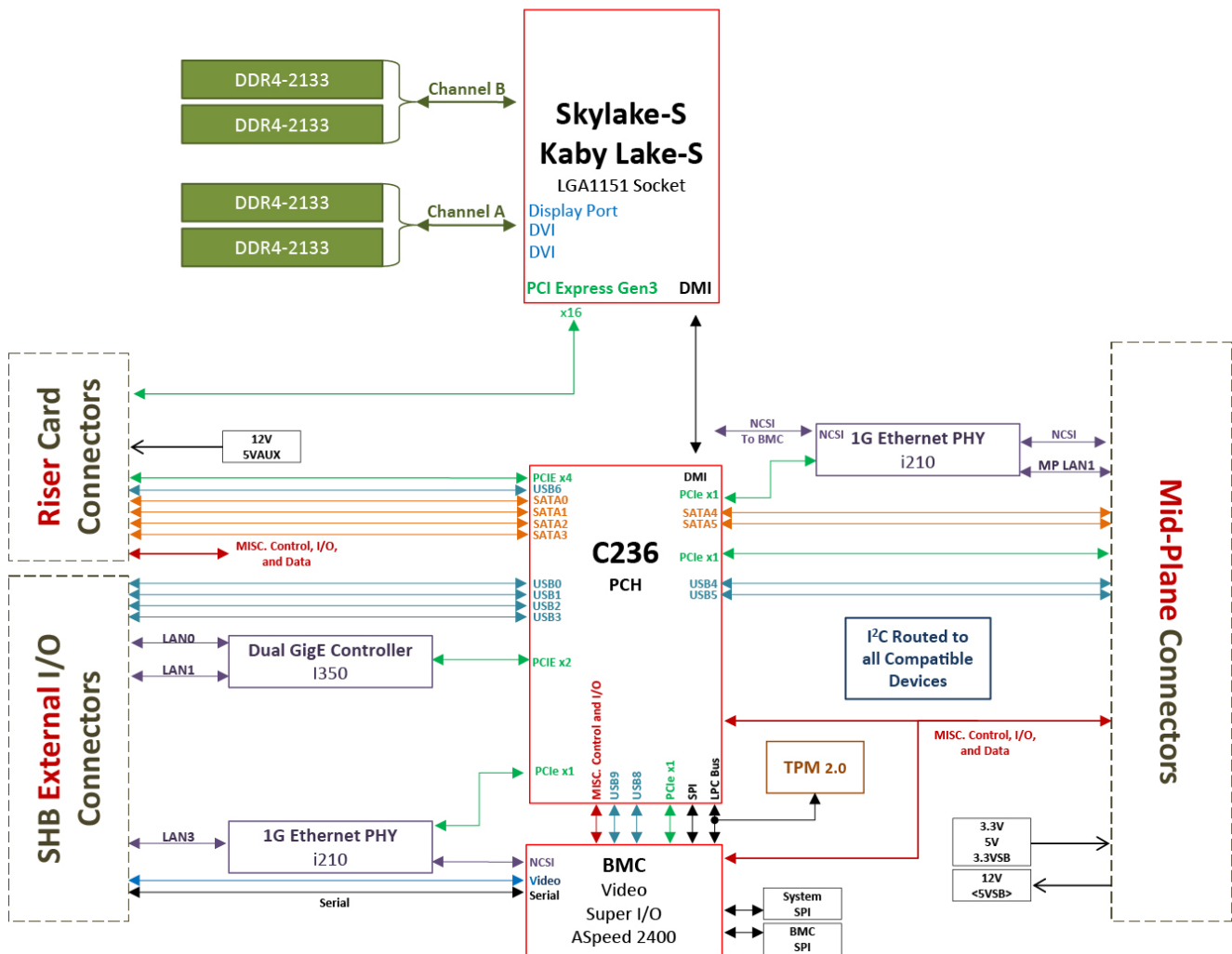

# LAYOUT DRAWING

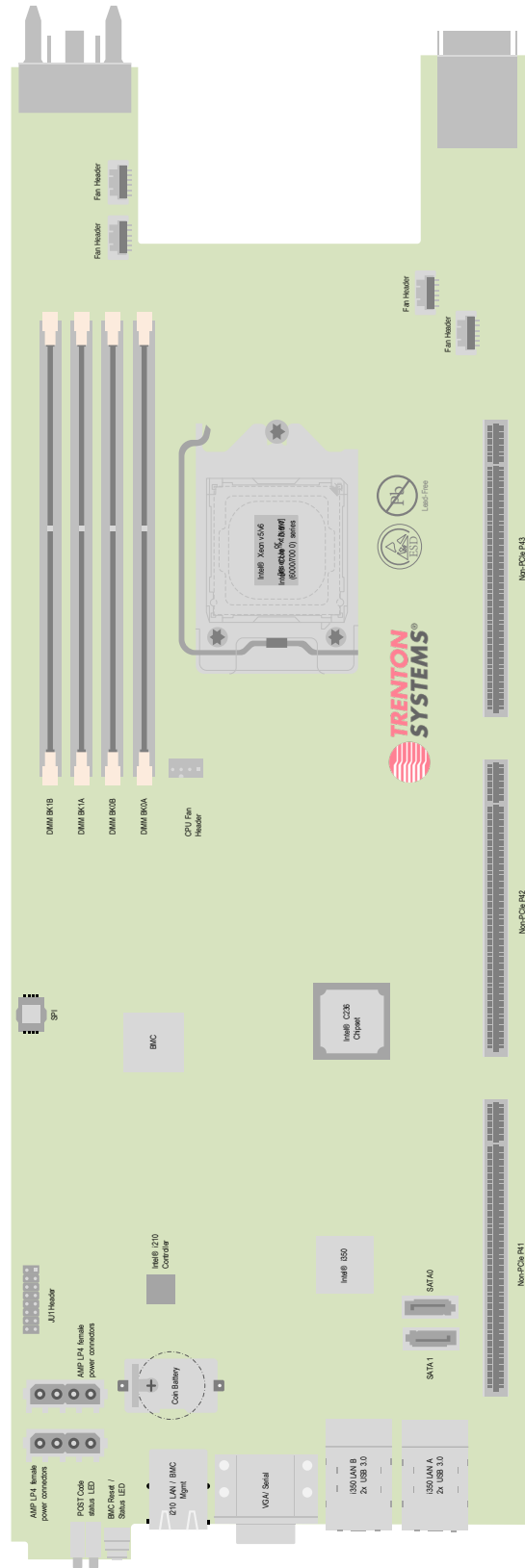

# Technical Specifications

## PROCESSORS

- ▶ Intel® Core™ i3, i5 and i7 and E3-1275 v6 Processors
- ▶ Processor plugs into an LGA1151 socket

### SUPPORTED INTEL® PROCESSOR TECHNOLOGIES

**Intel® Hyper-Threading (Intel® HT):** This processor technology allows simultaneous multithreading of CPU tasks to enable parallel system operations. An operating system that is hyper-threading aware can address each core as a logical processor in order to spread out execution tasks to improve application software efficiency and overall system speed.

**Intel Virtualization Technology (Intel® VT-x):** Enabled in the SHB's BIOS, this technology enables multiple operating systems to run in specific processor cores thereby creating virtual machines (VMs) on a single SHB.

**Intel Virtualization Technology for Directed I/O (Intel® VT-d):** This is a sub-set of Intel VT-x and enables I/O device assignments to specific processor cores or VMs. Intel VT-d also supports DMA remapping, interrupt remapping and software DMA and interrupt status reporting. Intel VT-d is an optional extension to the Intel VT-x technology.

**Intel® VT-x with Extended Page Tables (EPT):** This feature is enabled in the Skylake-S microarchitecture to support the processor's "real mode" or unrestricted guest feature.

**Intel Trusted Execution Technology (Intel® TXT):** This processor feature works in conjunction with the SHB's on-board Trusted Platform Module or TPM to allow the system designer to create multiple and separated execution environments or partitions with multiple levels of protection and security. The TPM provides for a way to generate and store an encrypted access key for authenticated access to sensitive applications and data. This private key never leaves the TPM, is generally available only to authorized system administrators, and enables remote assurance of a system's security state.

**Intel Turbo Boost Technology 2.0:** The higher performance Skylake-S processors may run above the processors stated clock speed via a new dynamic processor speed control technology called Intel Turbo Boost 2.0. The processor enters the boost mode when the operating system requests the highest possible performance state as defined by the Advanced Configuration and Power Interface or ACPI.





**Intel® Advanced Encryption Standard New Instructions (Intel® AES-NI):** Seven new instructions available in the Skylake-S micro-architecture makes pervasive encryption in an IT environment possible while enabling implementation that is faster and more affordable by providing advanced data protection and greater hardware platform security.

## **SERIAL INTERCONNECT INTERFACE**

PCI Express® 3.0, 2.0, and 1.1 compatible.

## **SERIAL INTERCONNECT SPEEDS**

- ▶ PCI Express 3.0 – 8.0GHz per lane
- ▶ PCI Express 2.0 – 5.0GHz per lane
- ▶ PCI Express 1.1 - 2.5GHz per lane

## **PLATFORM CONTROLLER HUB (PCH)**

- ▶ Intel® C236 Platform Controller Hub (Greenlow)

## **MEMORY INTERFACE**

The MBK8257 features two memory channels of unbuffered DDR4 with two DIMMs per channel for a maximum of 64GB of memory. These DDR4-2400 memory interface channels support up to four, unbuffered, ECC PC4-19200 standard memory DIMMs. Non-ECC DDR4 DIMMs are also supported, but the two memory types cannot be used together on the processor board. The peak memory interface transfer rate per channel is 2400MT/s when using PC4-19200 DIMMs.

The System BIOS automatically detects memory type, size and speed. Trenton Systems recommends unbuffered ECC PC4-19200 DDR4 memory modules for use on the MBK8257. These unbuffered ECC (64-bit) DDR4 DIMMs must be PC4-19200 compliant.

## **INTERRUPTS**

The processor board is fully PC compatible with interrupt steering for PCI plug and play compatibility.

## **BIOS (FLASH)**

The MBK8257 board uses an Aptio® 5.x BIOS from American Megatrends Inc. (AMI). The BIOS features built-in advanced CMOS setup for system parameters, peripheral management for configuring on-board peripherals and other system parameters. The BIOS resides in a 128Mb Macronix MX25L12835FM2I-10G SPI Serial EEPROM (SPI Flash). Custom BIOSs are available.



## CACHE MEMORY

The processors include either a 4MB, 6MB or 8MB Intel® Smart Cache memory capacity that is equally shared between all of the processor cores on the die.

## ETHERNET INTERFACES

The MBK8257 supports three Ethernet interfaces. The first two interfaces are on-board 10/100/1000Base-T Ethernet interfaces located on the board's I/O bracket and implemented using an Intel® i350 Dual Gigabit Ethernet Controller. These I/O bracket interfaces support Gigabit, 100Base-T and 10Base-TX Fast Ethernet modes and are compliant with the IEEE 802.3 Specification.

The main components of the Ethernet interfaces are:

- ▶ Intel® i350 for 10/100/1000-Mb/s Ethernet.
- ▶ Integrated RJ-45/Magnetics module connectors on the processor board's I/O bracket for direct connection to the network. The connectors require category 5 (CAT5) unshielded twisted-pair (UTP) 2-pair cables for a 100-Mb/s network connection or category3 (CAT3) or higher UTP 2-pair cables for a 10-Mb/s network connection. Category 5e (CAT5e) or higher UTP 2-pair cables are recommended for a 1000-Mb/s (Gigabit) network connection.
- ▶ Link status and activity LEDs on the I/O bracket for status indication (See Ethernet LEDs and Connectors later in this chapter.)

## TRUSTED PLATFORM MODULE

The MBK8257 provides support for Trusted Platform Module 2.0 operations via an Infineon SLB9665 controller. This feature aids in assuring platform integrity by providing a system designer the capability to form a root of trust in conjunction with the BIOS and system firmware.

## WATCHDOG TIMER (WDT)

The MBK8257 provides a programmable watchdog timer with programmable timeout periods of 1 msec to 1 minute. When enabled the WDT will generate a system reset. WDT control is supplied via the General Purpose IO pins from the Intel® C236 Platform Controller Hub (PCH). The PCH's WDT\_x GPIO signals are:

- ▶ WDT\_TRIG – GPP\_A23
- ▶ WDT\_SEL2 – GPP\_A22
- ▶ WDT\_SEL1 – GPP\_A21
- ▶ WDT\_SEL0 – GPP\_A20

As soon as the select lines are set to not-disabled, software needs to toggle the trigger within the timeout period or a reset occurs.



**Watchdog Timeout Period Selection:**

WATCH DOG TIMER INTERVALS			
GPP_A23 WDTSEL2	GPP_A21 WDTSEL1	APP_A20 WDTSELO	WDT TIMEOUT PERIOD
0	0	0	1msec
0	0	1	10msec
0	1	0	30msec
0	1	1	WDT DISABLED (default)
1	0	0	100msec
1	0	1	1sec
1	1	0	10sec
1	1	1	1min

**POWER REQUIREMENTS**

Actual power number will vary as a function of system application. Contact Trenton Systems for application-specific power figures.

**BATTERY**

A replaceable Panasonic lithium coin cell CR2032 battery is provided for ten years of data retention for CMOS memory.

**CAUTION:** There is a danger of explosion if the battery is incorrectly replaced. Replace it only with the same or equivalent type recommended by the battery manufacturer. Dispose of used batteries according to the battery manufacturer’s instructions.

**TEMPERATURE/ENVIRONMENT**

TYPE	DESCRIPTION
Operating Temperature	0° C. to 45° C for all CPU options
Air Flow Requirement	350LFM continuous airflow
Storage Temperature	- 40°C to 70°C
Humidity	5% to 90% non-condensing

**INDUSTRY CERTIFICATIONS**

This processor board is designed to meet a variety of internationally recognized industry standards including UL60950, CAN/CSA C22.2 No. 60950-00, EN55022:1998 Class B, EN6100-4-2:1995, EN61000-4-3:1997, EN61000-4-4:1995, EN61000-4-5:1995, EN61000-4-6:1996 and EN61000-4-11:1994.

## CONFIGURATION JUMPERS

The setup of the configuration jumpers on the processor board is described below. An asterisk (\*) indicates the default value of each jumper.

**NOTE:** Jumper JU1 is a dual-row, 16-pin jumper. Each position controls the operation of a specific SHB implementation.

PINS	PURPOSE
1-2	Install on pins 1 and 2 for normal operation
3-4	To clear CMOS: Remove and drain AC power. Move the shunt on PINS 1: 2 to 3:4 for a couple of seconds. Return the shunt from PINS 3:4 back to 1:2. Apply AC power and permit the system to land on the first boot device. The system will cycle power 2-3 times as part of this procedure, so do not be alarmed.
5-6	Flash security override
JU1 PINS 7:8	Password clear. For use: Drain AC power. Install a shunt on PINS 7:8 and boot to first boot device. Drain AC power, remove this shunt and boot as normal.

## STATUS LEDs

### POST Code LEDs 1 - 8

As the POST (Power On Self-Test) routines are performed during boot-up, test codes are displayed on Port 80 POST Code LEDs 0, 1, 2, 3, 4, 5, 6 and 7. These LEDs are located on the rear I/O panel of the module.

These POST codes may be helpful as a diagnostic tool. Specific test codes are listed in Appendix A - BIOS Messages section of the MBK8257 Technical Reference Manual. After a normal POST sequence, the LEDs are off (00h) indicating that the processor board's BIOS has passed control over to the operating system loader typically at interrupt INT19h. The chart is from Appendix A and can be used to interpret the LEDs into hexadecimal format during POST.

### P4A/P4B ETHERNET LEDS

The I/O bracket houses the three RJ-45 network connectors for Ethernet LAN1, LAN2, and LAN3. Each LAN interface connector has two LEDs that indicate activity status and Ethernet connection speed. Listed below are the possible LED conditions and status indications for each LAN connector:



LED/CONNECTOR	DESCRIPTION
Activity LED	This LED identifies the validity of a link on the specific interface. This is the upper LED on the LAN connector (i.e., toward the upper memory sockets).
Off	No valid link exists on this interface.
On (flashing)	Indicates network transmit or receive activity.
On (solid)	Indicates a valid link with no transmit or receive activity.
Speed LED	This multi-color LED identifies the connection speed of the SHB's P4A (LAN2) and P4B (LAN1) Ethernet interfaces. These are the lower LEDs on the dual LAN connector (i.e., toward the edge connectors).
Green	Indicates a valid link at 1000-Mb/s or 1Gb/s
Orange	Indicates a valid link at 100-Mb/s.
Off	Indicates a valid link at 10-Mb/s
RJ-45 Network Connectors	The RJ-45 network connector requires a Connector category 5 (CAT5) unshielded twisted-pair (UTP) 2-pair cable for a 100-Mb/s network connection or a category 3 (CAT3) or higher UTP 2-pair cable for a 10-Mb/s network connection. A category 5e (CAT5e) or higher UTP 2-pair cable is recommended for a 1000-Mb/s (Gigabit) network connection.



## SYSTEM BIOS SETUP UTILITY

The MBK8257 features the Aptio® BIOS from American Megatrends, Inc. (AMI) with a ROM-resident setup utility called the Aptio Text Setup Environment or TSE. The TSE setup utility allows you to select to the following categories of options:

- ▶ Main Menu
- ▶ Advanced Setup
- ▶ Boot Setup
- ▶ Security Setup
- ▶ Chipset Setup
- ▶ Exit

Each of these options allows you to review and/or change various setup features of your system. Contact Trenton for application-specific BIOS information and support.

*Trenton Systems is attaching a copy of American Megatrends Aptio 5.x Status Codes in this manual for your reference. This is a public document and the latest version can be downloaded at [https://ami.com/ami\\_downloads/Aptio\\_V\\_Status\\_Codes.pdf](https://ami.com/ami_downloads/Aptio_V_Status_Codes.pdf).*



**Trenton Systems**  
1725 MacLeod Drive  
Lawrenceville, GA 30043

[www.trentonsystems.com](http://www.trentonsystems.com)  
t. 770.287.3100  
e. [info@trentonsystems.com](mailto:info@trentonsystems.com)

