

Technical Information – Jumpers, Connectors, Memory Population Rules and Processor Memory Interface Support Details for the BXTS7059 (7059-xxx) Dual-Processor, PICMG 1.3 System Host Board

Layout Diagram

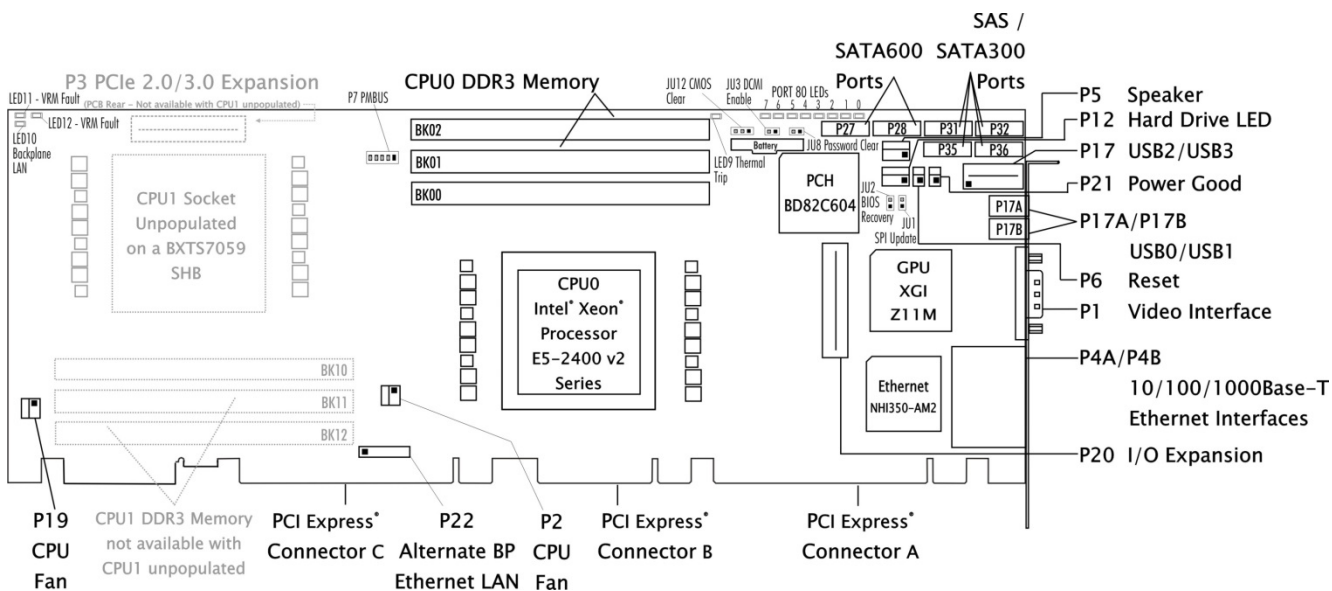

Jumpers & LEDs

The setup of the configuration jumpers on the SHB is described below. An asterisk (*) indicates the default value of each jumper.

NOTE: For the three-position JU12 jumper, "RIGHT" is toward the I/O bracket side of the board; "LEFT" is toward the CPU1 DDR3 Memory sockets.

JU1 SPI Update (two position jumper)

Install for one power-up cycle to enable the board to unprotect the SHB's SPI storage device.
Remove for normal operation. *

CAUTION: Installing this jumper is only done for special board operations such as changing the PCI Express link bifurcation operation. Contact Trenton tech support *before* installing this jumper to prevent any unintended system operation.

JU2 BIOS Recovery (two position jumper)

Install for one power-up cycle to recover factory default BIOS settings.
Remove for normal operation. *

JU3 DCMI Enable (two position jumper)

Install to enable Intel® Data Center Manageability Interface (Intel® DCMI) operation.
Remove for Intel® Advanced Management Technology (Intel® AMT 7.0) operation. *

NOTE: Intel® DCMI is an optional operating condition supported on the BXT7059. This mode of operation requires an updated SPI image since DCMI requires changes to the board's BIOS and management engine firmware. Contact Trenton for additional information.

Jumpers & LEDs (continued)

JU8 Password Clear (two position jumper)

Install for one power-up cycle to reset the password to the default (null password).

Remove for normal operation. *

JU12 CMOS Clear (three position jumper)

Install on the LEFT to clear.

Install on the RIGHT to operate. *

NOTE: To clear the CMOS, power down the system and install the JU12 jumper on the LEFT. Wait for at least two seconds, move the jumper back to the RIGHT and turn the power on. Clearing CMOS on the BXTS7059 will not result in a checksum error on the following boot. If you want to change a BIOS setting, you must press DEL or the F2 key during POST to enter BIOS setup after clearing CMOS.

P4A/P4B Ethernet LEDs

The I/O bracket houses the two RJ-45 network connectors for Ethernet LAN1 and LAN2. Each LAN interface connector has two LEDs that indicate activity status and Ethernet connection speed. Listed below are the possible LED conditions and status indications for each LAN connector:

LED/Connector Description

Activity LED	Yellow LED indicates network activity. This is the upper LED on the LAN connector (i.e., toward the upper memory sockets).
Off	No current network transmit or receive activity
On (solid)	Indicates a valid link established, but no network activity.
On (flashing)	Indicates network transmit or receive activity.
Speed LED	Green/Orange bi-color LED identifies the connection speed. This is the lower LED on the LAN connector (i.e., toward the edge connectors).
Off	Indicates a valid link at 10-Mb/s.
On (orange)	Indicates a valid link at 100-Mb/s.
On (green)	Indicates a valid link at 1000-Mb/s or 1-Gb/s.
RJ-45 Network Connectors	The RJ-45 network connector requires a Connectors category 5 (CAT5) unshielded twisted-pair (UTP) 2-pair cable for a 100-Mb/s network connection or a category 3 (CAT3) or higher UTP 2-pair cable for a 10-Mb/s network connection. A category 5e (CAT5e) or higher UTP 2-pair cable is recommended for a 1000-Mb/s (Gigabit) network connection.

Jumpers & LEDs (continued)

LED9 ERROR LED

The error LED indicates several different error conditions noted below. The LED is located just above the BK02 DIMM socket.

LED Status	Description
Off	Indicates the normal board operation.
On (solid)	Indicates a CPU is throttling down to a lower operating speed due to rising CPU temperature. Indicates the CPU has reached the thermal shutdown threshold limit. The SHB may or may not be operating, but a board shutdown condition will soon occur
On (fast blink rate)	Indicates a catastrophic error condition has occurred. The SHB suspends system operation until the error condition is corrected. Contact Trenton tech support.
On (slow blink rate)	A potential error condition has been detected. The SHB continues to operate, but the system should be checked for errors.

NOTE: When a thermal shutdown occurs, the LED will stay on in systems using non- ATX/EPS power supplies. The CPU will cease functioning, but power will still be applied to the SHB. In systems with ATX/EPS power supplies, the LED will turn off when a thermal shutdown occurs because system power is removed via the ACPI soft control power signal S5. In this case, all SHB LEDs will turn off; however, stand-by power will still be present.

LED10 Backplane LAN LED

The backplane LAN LED is located below LED11 in the upper left corner of the board. This LED indicated the status of the Ethernet communications link between the SHB and the backplane as show below:

LED Status	Description
Off	Indicates LAN is inactive and link communications have not been established
On (flashing)	Indicates data is being transferred between the SHB and the backplane
On (solid)	Indicates the LAN has a valid link and is ready for data transfers

LED11 VRM LEDs and LED12

These LEDs monitor the status on the power circuits associated with the SHBs processors.

LED Status	Description
Off	All power circuits are operating within acceptable limits and driving the CPUs correctly.
On	The CPUs have shut down most likely due to a VRM fault. Contact Trenton for assistance

Jumpers & LEDs (continued)

POST Code LEDs 0 - 7

As the POST (Power On Self Test) routines are performed during boot-up, test codes are displayed on Port 80 POST Code LEDs 0, 1, 2, 3, 4, 5, 6 and 7. These LED are located on the top of the SHB, just above the board's battery socket. The POST Code LEDs are numbered from right (position 1 = LED0) to left (position 8 – LED7). Refer to the board layout diagram for the exact location of the POST code LEDs.

These POST codes may be helpful as a diagnostic tool. Specific test codes are listed in Appendix A - BIOS Messages section of the BXTS7059 Technical Reference Manual. After a normal POST sequence the LEDs are off (00h) indicating that the SHB's BIOS has passed control over to the operating system loader typically at interrupt INT19h. The chart is from Appendix A and can be used to interpret the LEDs into hexadecimal format during POST.

Upper Nibble (UN)				
Hex. Value	LED7	LED6	LED5	LED4
0	Off	Off	Off	Off
1	Off	Off	Off	On
2	Off	Off	On	Off
3	Off	Off	On	On
4	Off	On	Off	Off
5	Off	On	Off	On
6	Off	On	On	Off
7	Off	On	On	On
8	On	Off	Off	Off
9	On	Off	Off	On
A	On	Off	On	Off
B	On	Off	On	On
C	On	On	Off	Off
D	On	On	Off	On
E	On	On	On	Off
F	On	On	On	On

Lower Nibble (LN)				
Hex. Value	LED3	LED2	LED1	LED0
0	Off	Off	Off	Off
1	Off	Off	Off	On
2	Off	Off	On	Off
3	Off	Off	On	On
4	Off	On	Off	Off
5	Off	On	Off	On
6	Off	On	On	Off
7	Off	On	On	On
8	On	Off	Off	Off
9	On	Off	Off	On
A	On	Off	On	Off
B	On	Off	On	On
C	On	On	Off	Off
D	On	On	Off	On
E	On	On	On	Off
F	On	On	On	On

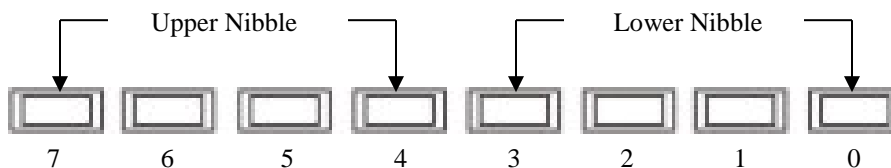

BXTS7059 POST Code LEDs

Connectors

NOTE:

A connectors square solder pad located on the bottom side of the PCB indicates pin 1.

P4A/P4B – Dual 10/100/1000Base-T Ethernet Connector - LAN1 and LAN2

RJ-45/Dual connector, Pulse #JG0-0024NL

Each individual RJ-45 connector is defined as follows:

PIN	SIGNAL	PIN	SIGNAL
1A	L2_MDI0n	1B	L1_MDI0n
2A	L2_MDI0p	2B	L1_MDI0p
3A	L2_MDI1n	3B	L1_MDI1n
4A	L2_MDI1p	4B	L1_MDI1p
5A	L2_MDI2n	5B	L1_MDI2n
6A	L2_MDI2p	6B	L1_MDI2p
7A	L2_MDI3n	7B	L1_MDI3n
8A	L2_MDI3p	8B	L1_MDI3p
9A	VCC_1.8V	9B	VCC_1.8V
10A	GND_A	10B	GND_b

Notes:

- 1 – LAN ports support standard CAT5 Ethernet cables
- 2 – P4A is LAN2 and P4B is LAN1

P1 –Video Connector

15-pin Video connector, Amp 1-1734530-3:

PIN	SIGNAL	PIN	SIGNAL
1	Red	9	+5V
2	Green	10	Gnd
3	Blue	11	NC
4	NC	12	EEDI
5	Gnd	13	HSYNC
6	Gnd	14	VSYNC
7	Gnd	15	EECS
8	Gnd		

Note:

- 1 – Video connector supports standard video cables

P17 – Dual Universal Serial Bus (USB) Connector

10 pin dual row header, Molex #702-46-1001 (+5V fused with self-resetting fuse)

PIN	P17 SIGNAL	PIN	P17 SIGNAL
1	+5V-USB2	2	+5V-USB3
3	USB2-	4	USB3-
5	USB2+	6	USB3+
7	Gnd-USB2	8	Gnd-USB3
9	NC	10	NC

Note:

- 1 – P17 odd pins are for USB2 and the even pins are USB3

P17A, P17B – Universal Serial Bus (USB) Connectors (I/O Bracket)

USB vertical connectors, Molex #47500-0001 (+5V fused with self-resetting fuse)

PIN	P17A SIGNAL	PIN	P17B SIGNAL
1	+5V-USB0	1	+5V-USB1
2	USB0-	2	USB1-
3	USB0+	3	USB1+
4	Gnd-USB0	4	Gnd-USB1

Note:

- 1 – P17A is USB0 and P17B is USB1

P27, P28 – SATA III 600 / SATA II 300 Ports

7 pin vertical connector with latch, Molex #67800-8005

PIN	SIGNAL	PIN	SIGNAL
1	Gnd	5	RX-
2	TX+	6	RX+
3	TX-	7	Gnd
4	Gnd		

Notes:

- 1 – P27 = SATA0 interface, P28 = SATA1 interface

Connectors (continued)

P2 and P19 – CPU Fan Power Connectors

3 pin single row header, Molex #22-23-2031

PIN	SIGNAL
1	Gnd
2	+12V
3	Fan Tach

P2 fan connector is available, but not used on a JXTS6966 with the CPU2 socket unpopulated

Note:

1 – P2 is the fan connector for CPU2 and P19 is for CPU1

P5 - SPEAKER PORT CONNECTOR

4 pin single row header, Amp #640456-4

PIN	SIGNAL
1	Speaker Data
2	Key
3	Gnd
4	+5V

P6 - Reset Connector

2 pin single row header, Amp #640456-2

PIN	SIGNAL
1	Gnd
2	Reset In

P7 - PMBUS Connector

5 pin single row Mini MI2 header, Molex # 554470570
(For use in optional DCMI applications only)

PIN	SIGNAL
1	SMCLK_Link1
2	SMDATA_Link1
3	PMBUS_Alert#
4	GND
5	+3.3V

P31, P32, P35, P36 – SAS / SATA II 300 Ports

7 pin vertical connector with latch, Molex #67800-8005

PIN	SIGNAL	PIN	SIGNAL
1	Gnd	5	RX-
2	TX+	6	RX+
3	TX-	7	Gnd
4	Gnd		

Notes:

1 – P31 = SAS0/SATA interface, P32 = SAS1/SATA interface,
P35 = SAS2/SATA interface, P36 = SAS3/SATA interface

P12 – Hard Drive LED Connector

4 pin single row header, Amp #640456-4

PIN	SIGNAL
1	LED +
2	LED -
3	LED -
4	LED +

P21 – POWER GOOD LED

2 pin single row header, Amp #640456-2

PIN	SIGNAL
1	LED -
2	LED +

P22 - 10/100/1000Base-T Ethernet Connector – Alternate Backplane LAN Over Cable

8 pin single row connector, Molex #0554500859

PIN	SIGNAL
1	A_MDI2N
2	A_MDI2P
3	A_MDI3N
4	A_MDI3P
5	A_MDI1N
6	A_MDI1P
7	A_MDI0N
8	A_MDI0P

BP LAN Cable Option

You may elect to create your own backplane LAN cable using the mating Molex connector information below. However, Trenton Systems does offer a pre-made alternate backplane LAN cable with the mating Molex connector on one end and an RJ45 connector mounted into an I/O bracket on the other end. The Trenton part number for the alternate backplane LAN cable is: **193500001150-00**.

Note: Using the alternate backplane LAN cable effectively disconnects the LAN routing down to SHB edge connector C.

Note: The mating Molex connector to use when making this alternative Ethernet cable has a Molex part number of 0513360810.

Connectors (continued)

P20 - I/O Expansion Mezzanine Card Connector (For IOBxx option modules)

76 pin controlled impedance connector, Samtec #MIS-038-01-FD-K

PIN	SIGNAL	PIN	SIGNAL
1	+12V	2	+5V_STANDBY
3	HDA_SDIN2	4	+5V_STANDBY
5	HDA_SDIN1	6	+5V_DUAL
7	HDA_SDIN0	8	+5V_DUAL
9	HDA_SYNC	10	HDA_BITCLK
11	HDA_SDOUT	12	HDA_ACRST
13	ICH_SMI#	14	ICH_RCIN#
15	ICH_SIOPME#	16	ICH_A20GATE
17	Gnd	18	Gnd
19	L_FRAME#	20	L_AD3
21	L_DRQ1#	22	L_AD2
23	L_DRQ0#	24	L_AD1
25	SERIRQ	26	L_AD0
27	Gnd	28	Gnd
29	PCLK14SIO	30	PCLK33LPC
31	Gnd	32	Gnd
33	SMBDATA_RESUME	34	IPMB_DAT
35	SMBCLK_RESUME	36	IPMB_CLK
37	SALRT#_RESUME	38	IPMB_ALRT#
39	Gnd	40	Gnd
41	EXP_CLK100	42	EXP_RESET#
43	EXP_CLK100#	44	ICH_WAKE#
45	Gnd	46	Gnd
47	C_PE_TXP5	48	C_PE_RXP5
49	C_PE_TXN5	50	C_PE_RXN5
51	Gnd	52	Gnd
53	NC	54	NC
55	NC	56	NC
57	Gnd	58	Gnd
59	NC	60	NC
61	NC	62	NC
63	Gnd	64	Gnd
65	NC	66	NC
67	NC	68	NC
69	Gnd	70	Gnd
71	+3.3V	72	+5V
73	+3.3V	74	+5V
75	+3.3V	76	+5V

P3 – PCI Express Gen 2.0 Expansion Connector

(For PEX10 option module with CPU2 installed – Not active on a JXTS with CPU2 not populated)

80-pin (40 differential pairs) high-speed socket strip, Samtec #QSH-040-01-F-D-DP

PIN	SIGNAL	PIN	SIGNAL
Pins 1 to 8 = No Connection (NC)			
9	P1_PE_RXN15	10	P1_PE_TXN15
11	P1_PE_RXP15	12	P1_PE_TXP15
13	P1_PE_RXN14	14	P1_PE_TXN14
15	P1_PE_RXP14	16	P1_PE_TXP14
17	P1_PE_RXN13	18	P1_PE_TXN13
19	P1_PE_RXP13	20	P1_PE_TXP13
21	P1_PE_RXN12	22	P1_PE_TXN12
23	P1_PE_RXP12	24	P1_PE_TXP12
25	P1_PE_RXN11	26	P1_PE_TXN11
27	P1_PE_RXP11	28	P1_PE_TXP11
29	P1_PE_RXN10	30	P1_PE_TXN10
31	P1_PE_RXP10	32	P1_PE_TXP10
33	P1_PE_RXN9	34	P1_PE_TXN9
35	P1_PE_RXP9	36	P1_PE_TXP9
37	P1_PE_RXN8	38	P1_PE_TXN8
39	P1_PE_RXP8	40	P1_PE_TXP8
41	NC	42	NC
43	NC	44	NC
45	P1_PE_CFG2	46	P1_PE_CFG1
47	P1_GEN2_DSBL#	48	P1_PE_CFG0
49	P1_PE_RXN7	50	P1_PE_TXN7
51	P1_PE_RXP7	52	P1_PE_TXP7
53	P1_PE_RXN6	54	P1_PE_TXN6
55	P1_PE_RXP6	56	P1_PE_TXP6
57	P1_PE_RXN5	58	P1_PE_TXN5
59	P1_PE_RXP5	60	P1_PE_TXP5
61	P1_PE_RXN4	62	P1_PE_TXN4
63	P1_PE_RXP4	64	P1_PE_TXP4
65	P1_PE_RXN3	66	P1_PE_TXN3
67	P1_PE_RXP3	68	P1_PE_TXP3
69	P1_PE_RXN2	70	P1_PE_TXN2
71	P1_PE_RXP2	72	P1_PE_TXP2
73	P1_PE_RXN1	74	P1_PE_TXN1
75	P1_PE_RXP1	76	P1_PE_TXP1
77	P1_PE_RXN0	78	P1_PE_TXN0
79	P1_PE_RXP0	80	P1_PE_TXP0

NOTE: Need CPU2 installed for PCI Express expansion

Memory

The processor on the BXTS7059 SHB supports three direct-connect DDR3 memory interfaces. The maximum possible memory interface speed obtained depends on the specific Intel® Xeon® E5-2400 v2 or Intel® Xeon® E5-2400 series processor used on the board and other board configuration options listed in the notes section below. The table below illustrates the maximum DDR3 **memory speed** supported as a function of each specific Intel® Xeon® processor when using the recommended PC3-12800 compliant Mini-DIMM modules and an SHB with the latest BIOS support.

Max. DDR3 Speed	Processor	Cores / Threads	Cache	Long-Life Availability	Maximum Thermal Design Power (TDP)	Operating Temperature Range*
DDR3-1600	Intel® Xeon® E5-2450 v2	8 / 16	20MB	Yes	95W	0°C to 40°C
DDR3-1600	Intel® Xeon® E5-2430 v2	6 / 12	15MB	Yes	80W	0°C to 50°C
DDR3-1600	Intel® Xeon® E5-2448L v2	10 / 20	25MB	Yes	70W	0°C to 50°C
DDR3-1600	Intel® Xeon® E5-2428L v2	8 / 16	20MB	Yes	60W	0°C to 50°C
DDR3-1333	Intel® Xeon® E5-2418L v2	6 / 12	15MB	Yes	50W	0°C to 50°C
DDR3-1600	Intel® Xeon® E5-2448L	8 / 16	20MB	Yes	70W	0°C to 50°C
DDR3-1333	Intel® Xeon® E5-2430	6 / 12	15MB	Yes	95W	0°C to 50°C
DDR3-1333	Intel® Xeon® E5-2428L	6 / 12	15MB	Yes	60W	0°C to 50°C
DDR3-1333	Intel® Xeon® E5-2418L	4 / 8	10MB	Yes	50W	0°C to 50°C

*Requires a continuous airflow across the board of 350LFM.

All processor options listed above support Intel® Hyper-Threading. All processors *except* the Intel® Xeon® E5-2418L v2 support Intel® Turbo Boost Technology.

A. There are three active DDR3 Mini-DIMM sockets on the board and each one can support a 16GB Mini-DIMM for a total possible DDR3 system memory capacity of 48GB. 24GB is the maximum practical memory capacity since 8GB Mini-DIMMs are readily available. The processor's three individual direct-connect memory channel interfaces terminate with a single in-line Mini-DIMM memory module socket BK##. The System BIOS automatically detects memory type, size and speed.

B. Trenton recommends ECC registered DDR3-1600 Mini-DIMM memory modules for use on the BXTS7059 and these ECC registered (72-bit) DDR3 Mini-DIMMs must be PC3-12800 compliant. Unbuffered ECC DDR3 Mini-DIMMs are also supported on the BXTS7059 SHB, but you cannot mix the two different memory types on the same board.

C. The SHB uses industry standard gold finger Mini-DIMM memory modules, which must be PC3-12800 compliant and have the following features: 244-pin, gold-plated contacts and ECC registered (72-bit) DDR3-1600 memory.

D. The following Mini-DIMM sizes are supported:

MT/s	Mini-DIMM Type	Rank	Component Density
1600	PC3-12800	Single, Dual, Quad	1GB, 2GB, 4GB, 8GB, 12GB

NOTE 1: To maximize memory interface speed, populate each memory channel with DDR3-1600 Mini-DIMMs.

NOTE 2: Low-voltage (DDR3L) Mini-DIMMs are not supported.

NOTE 3: The SHB supports the following memory module memory latency timings:

- 9-9-9 for 1600MHz DDR3 Mini-DIMMs

NOTE 4: Populate the memory sockets starting with the Mini-DIMM socket closest to the CPU and work your way toward the edges of the SHB as illustrated in the chart below:

Mini-DIMM Population Order	CPU1
1	BK00
2	BK01
3	BK02

For additional BXTS7059 product and systems information visit the Trenton Systems website at: [BXTS7059 Product Detail](#)